



dust filter controls

Product Data Sheet

3WKX74041RJDP

3 Valve Rev. Jet Station



OVERVIEW

- *The **KX** range is designed to serve reverse jet dust extraction systems and formulated specifically to address their needs. The **3WKX74041RJDP Rev. Jet Station** is intended for small (up to 3 valves) installations but incorporates many of the features only found in much larger systems. This unit offers the latest in Microprocessor technology in a compact enclosure, affording unparalleled levels of user friendliness, system flexibility and tamper-proof operation.*
- *The **3WKX74041RJDP Rev. Jet Station** takes care of system control. Using just four pushbuttons and the high resolution LCD Display, all aspects of system operation can easily be programmed for optimum performance. A tamper-proof version of the Controller is available.*



dust filter controls

Circuit Control Technology
48 Boston Road
Gorse Hill Industrial Estate
Beaumont Leys, Leicester, LE4 1AA
Tel: +44 (0) 116 2998000
Fax: +44 (0) 116 2998001
e-mail: sales@dustfiltercontrols.co.uk

CCT REV XC/22.02.2013

Features

ADVANCED MICRO-PROCESSOR CONTROL

- Operating at over a million instructions per second the onboard micro-processor provides ease of use and a level of control which was virtually impossible with old plc or Cmos systems.

ONBOARD EPROM MEMORY

- Ensures system settings are retained during power failure or whilst power is turned off.

EASY TO USE 4 BUTTON CONTROL

- **MODE:** Move forward through options
- **UP:** Increases values selected by mode
- **DOWN:** Decreases values selected by mode
- **START/STOP:** Run or halt the system

HIGH RESOLUTION LCD DISPLAY

- Easily view and adjust system setup.
- Displays pressure readings in real time.
- Monitor system status

BUILT-IN DIFFERENTIAL PRESSURE SENSOR

- The 3WKX74041RJDP has it's own internal differential pressure sensor which allows the unit to clean only when needed. This also dispenses with the need for additional external devices.

REAL TIME SYSTEM MONITORING

- While the system is running, Differential Pressure and system status can be monitored in real time. Differential pressure is displayed constantly whenever the Controller is running (dp sensor switched on) along with the number of the current valve to be fired during the cleaning sequence. One quick glance at the display will tell the operator the current state of the system and the current position in the cleaning cycle.

BUILT-IN OUTPUT AMPLIFIERS AND POWER SUPPLY

- The unit has it's own internal 24 Volt Power supply. Power output to solenoid valves is provided directly from the controller using the internal power amplifiers .

CLEANING FAILURE WARNING

- The system is designed to expect effective cleaning to have taken place within five full cycles, if this is not the case a visual and (where fitted) an audible warning will sound.

SEPARATE CLEANING CYCLE FOR SYSTEM FAN STOP

- A separately programmable cleaning cycle is provided for optimum filter performance. This operates whilst the main system fan is not running and can be set to operate for a set number of cycles.



dust filter controls

Technical Specifications

CONTROLLER:	Part Number 3WKX74041RJDP.
INPUT SUPPLY:	115 - 230 V +10% -15% @ 50/60HZ.
INPUT FUSES:	Fuse 1: 1 Amp 230 V HBC 20mm .
VALVE OUTPUT FUSE:	Fuse 2: 2.5 Amp 24 V HBC 20mm.
INPUT CONNECTIONS:	3-Way 1.5mm 10 Amp side entry plug and socket insulated terminal block which is marked: 230, 115, Neut .
MAINS FAILURE:	In the event of mains failure, the unit will operate to specification as soon as the voltage level comes within the above limits.
OUTPUT VOLTAGE:	24V DC, regulation as input.
OUTPUT LOAD PER OUTLET:	36W continuous, 44W pulsed into solenoid valves.
I.O. CONNECTIONS:	1.5mm 10 Amp side entry plug and socket insulated terminal <i>control inputs:</i> marked: control inputs 5v, fan <i>valve outputs:</i> marked: valve outputs 4 - and common.
DP PRESSURE CONNECTIONS:	2 x 5mm (outside diam) pneumatic compression connectors suitable to accept nylon hose.
START UP SEQUENCE:	The unit is arranged so that it will always start at output 1.
PRESSURE SCALE:	0 - 700mmWG.
CONSTRUCTION:	Solid state microprocessor components mounted onto a double-sided glass fibre P.C.B. with component mask.
INDICATION:	Valve Numbers 1-3 will be displayed as each output is energised in sequence.
AMBIENT TEMPERATURE AT BOARD SURFACE:	0 to +45 deg.C. Storage Temperature: -10 to +60 deg.C.
VIBRATION SPEC:	Not greater than BEAMA Group 2.
CONDUCTING MATERIALS:	Standard P.C.B's can be supplied with their surfaces coated with a layer of Parylene C, a material that is to MOD standard 59-47/4, and MIL-1-460C. This treatment reduces the risk of damage through moisture.
MICRO-PRO SEQUENCER:	Hinge opening Polycarbonate box with clear LCD window. Lower panel with 2 retaining screws houses terminals. Size 195 x 94 x 160mm.

CCT reserve the right to change product specifications at any time with out prior notification and as a consequence of on-going product development.

Programmable features

The following is a flow chart of the programmable settings available on the 3WKX74041RJDP Valve Controller. The options available in each mode are explained in an easy to follow format.

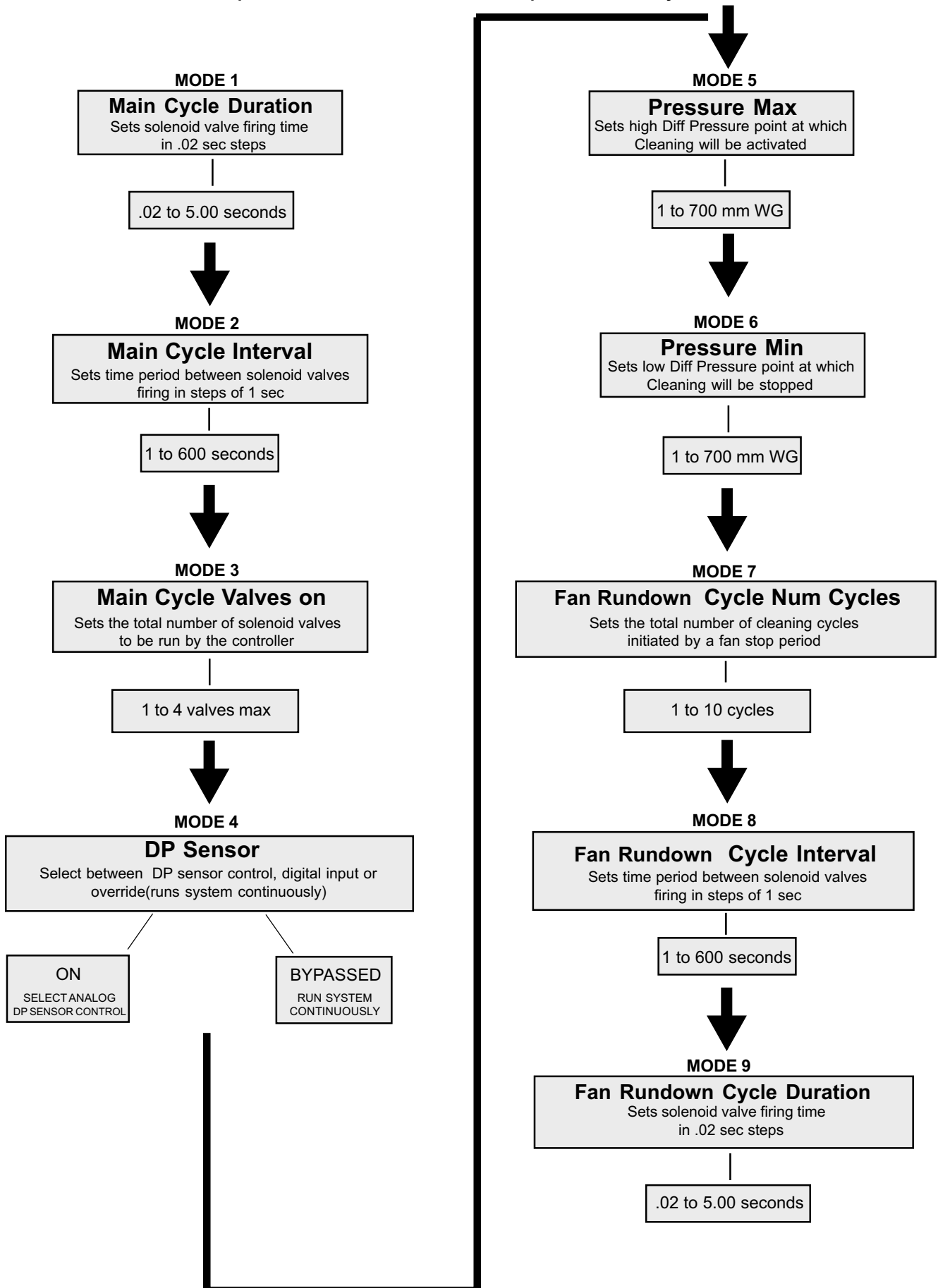

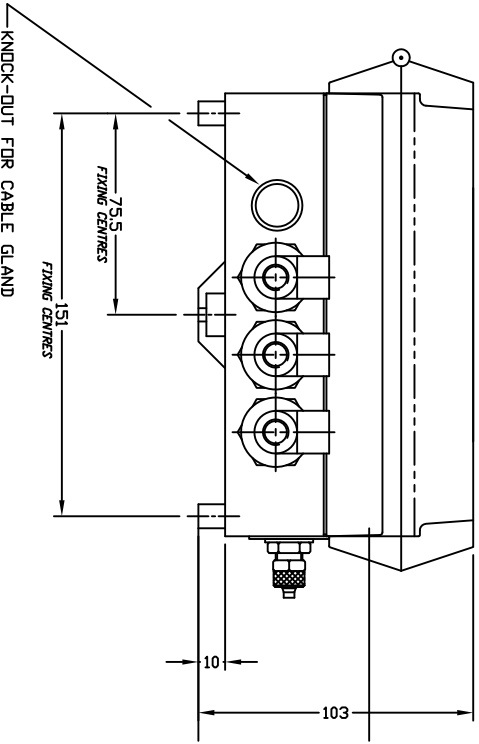
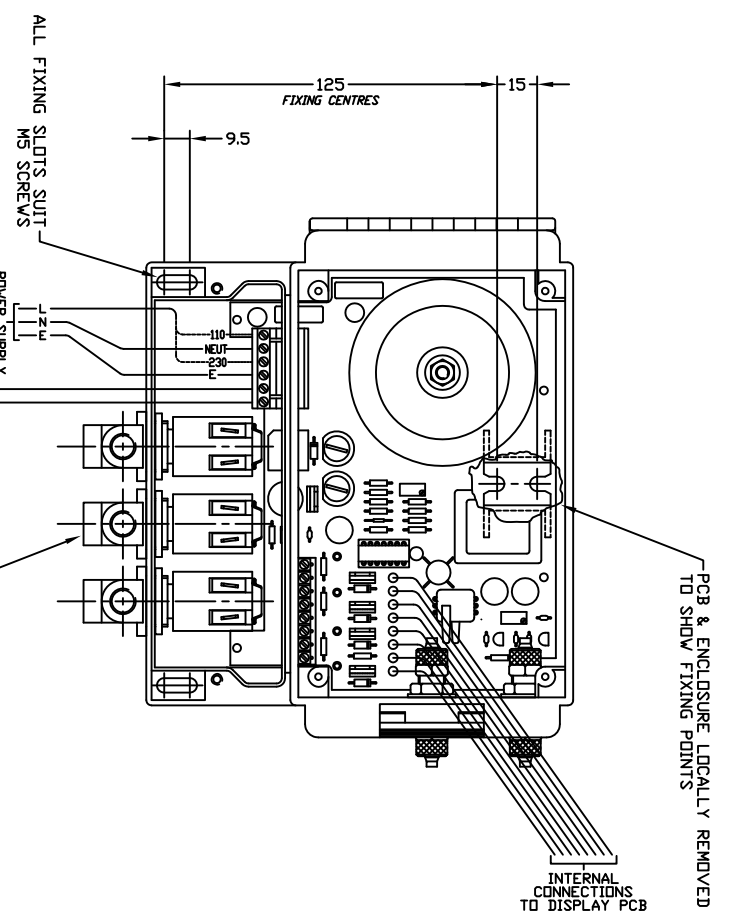
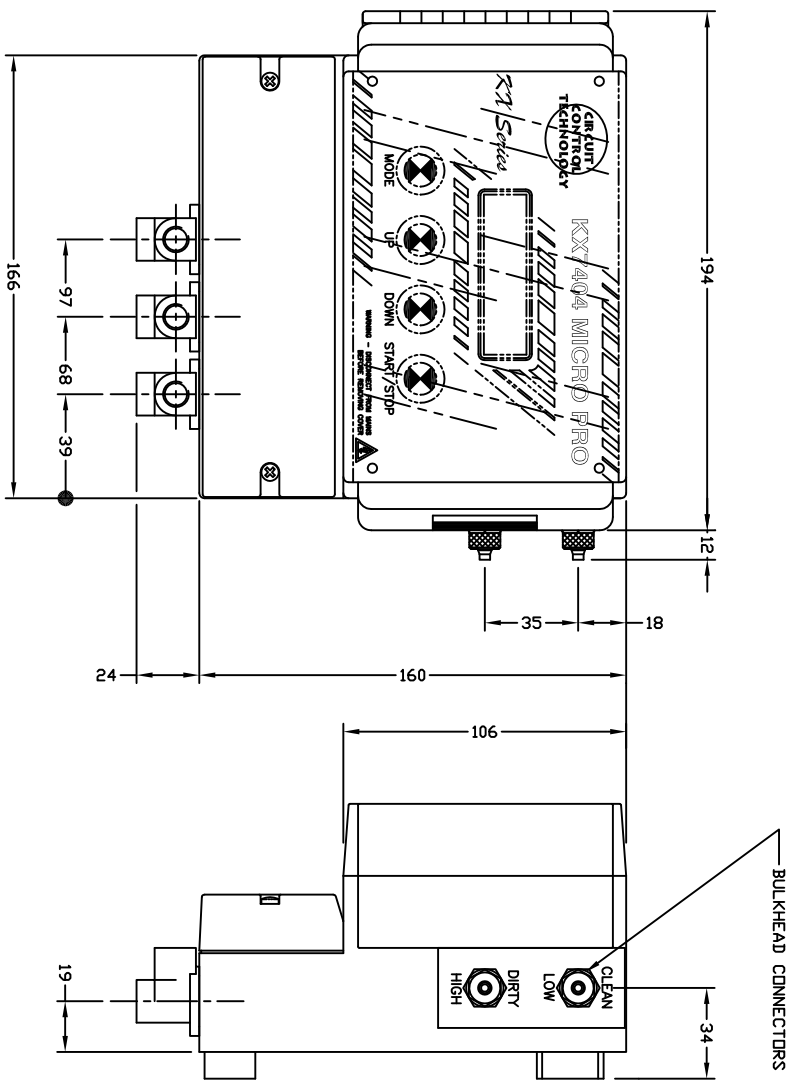

VIEW WITH COVERS & DISPLAY PANEL OMITTED
TO SHOW FIXINGS & FIELD CONNECTIONS

CIRCUIT CONTROL TECHNOLOGY.

48 BOSTON ROAD,
GORSE HILL INDUSTRIAL ESTATE,
BEAUMONT LEYS, LEICESTER, LE4 1AA
Tel: +44 (0) 116 2998000 Fax: +44 (0) 116 2998001

Part No: 3MKX74041RJD

Title: 3 VALVES
REV JET STATION
GENERAL ARRANGEMENT

Issue	Description	Date
B	CCT LOGO ADDED	14.07.11
A	PRELIMINARY	03.02.03
Drwn.	LOF	03.02.03
Chkd.	/	/
Appd.	/	/

THIS DRAWING IS THE COPYRIGHT OF CIRCUIT CONTROL TECHNOLOGY AND MAY NOT BE COPIED, TRANSMITTED NOR USED FOR ANY PURPOSE OTHER THAN THAT FOR WHICH IT WAS INTENDED, WITHOUT THEIR WRITTEN PERMISSION.

CADFile: KX00\KX74041A Plot Date: 03.02.03

Dwg. No. KX74041 Rev. B

Sheet 1 of 1