

F Series



CHARACTERISTICS

Fluid	Filtered and oilfree compressed air
Temperature range	STD diaphragm -40°C; +80°C Viton diaphragm -30°C; +200°C
Operating pressure	min. 0,5; max 7,5 bar
Body e cover	Die cast aluminium
Core tube	Stainless Steel
Plunger	Stainless Steel
Screws	Stainless Steel
Coil insulation	Class H
Connector	PG 9; IP65 DIN 43650 ISO 4400
Standard voltage	230 -110 - 24V / 50-60VHz 19 VA 24VDC 15W

DESCRIPTION	FP/FM20	FP/FM25
1 Coil+Connector	BH10...V/50-60Hz	BH10...V/50-60Hz
2 Screws+Washer	VTE6x20+VROS6	VTE6x20+VROS6
3 Pole assembly	GPC 10	GPC 10
4 Cover	TCOP 25	TCOP 25
5 Diaphragm	M25	M25
6 Body	TCOR20FFG	TCOR20FFG
7 Cover remote operated	TCOP25FM	TCOP25FM

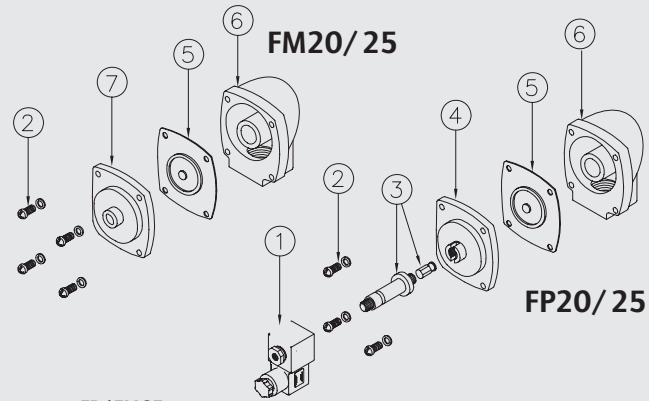

FP Integral solenoid pilot version
FM Remote pilot version

DESCRIPTION	FP/FM40	FP/FM55	FP/FM65
1 Coil+Connector	BH10...V/50-60Hz	BH10...V/50-60Hz	BH10...V/50-60Hz
2 Screws+Washer	VTE6x20+VROS6	VTE6x20+VROS6	VTE6x20+VROS6
3 Pole assembly	GPC 10	GPC 10	GPC 10
4 Cover	TCOP 25	TCOP 25	TCOP 25
5 Diaphragm	M25	M25	M25
6 Screws + Washer	VTE8x20+VROS8	VTE10x25+VROS10	VTE10x25+VROS10
7 Main cover	TCOP 40	TCOP 65G	TCOP 65G
8 Spring	TMOL40	TMOL40	TMOL40
9 Main diaphragm	M40	M55	M75
10 Body	TCOR40FFG	TCOR55FFG	TCOR65FFG
11 Cover remote operated	TCOP25FM	TCOP25FM	TCOP25FM

FP Integral solenoid pilot version
FM Remote pilot version

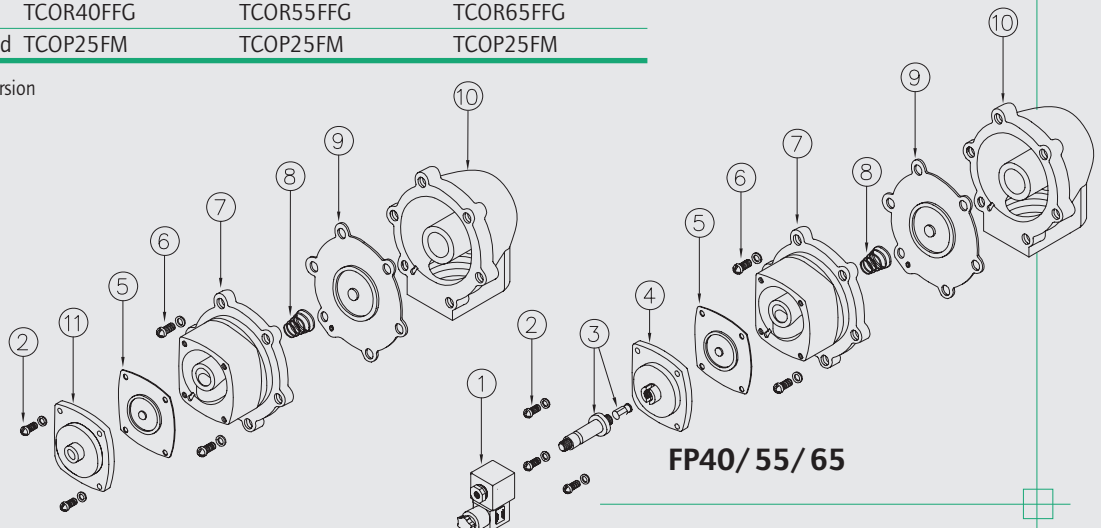

Dimension mm **F** Series

FP20 - FP25

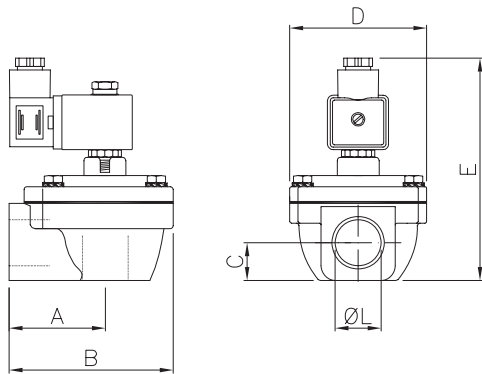

FM20 - FM25

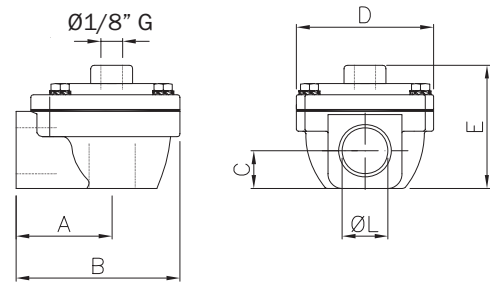

FP40 - FP55 - FP65

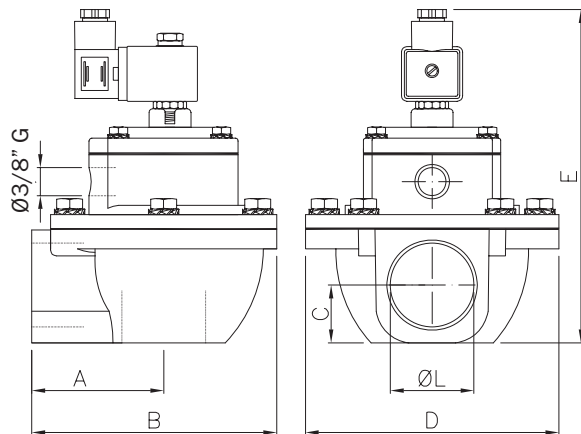

FM40 - FM55 - FM65

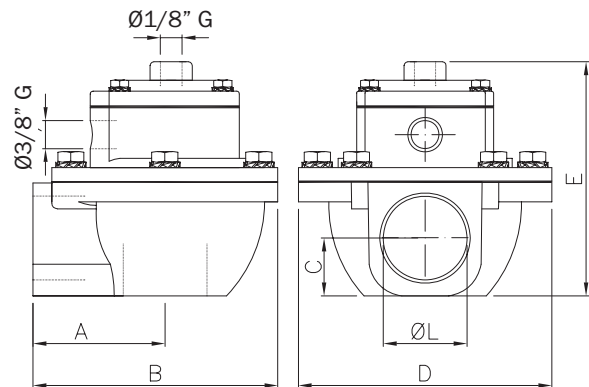

Model	Ø L (nom)	A	B	C	D	E	Weight (Kg)	Model	E	Weight (Kg)
FP 20	3/4"	52	90	20,5	74	~125	0,6	FM 20	67	0,4
FP 25	1"	52	90	20,5	74	~125	0,5	FM 25	67	0,4
FP 40	1 1/2"	71,3	135	31	140	~188	1,6	FM 40	130	1,4
FP 55	2"	114	203	40	194	~225	3,5	FM 55	167	3,4
FP 65	2 1/2"	114	203	48	194	~225	3,4	FM 65	167	3,2